



**RJ-107102-101 JL & JT ECODIESEL FRONT BUMP STOP KIT (ALSO FITS JK)
INSTALLATION INSTRUCTIONS & TECHNICAL MANUAL**



Thank you for purchasing our JL, JT & JK front bump stop kit! This kit is specifically design for use with and included in our JL & JT EcoDiesel suspension kits, but may be used in all JL, JT & JK applications if it is determined that this unit is ideal for your application.

Kit Includes

- 2) RJ-107102-1.....Billet Aluminum Bump Stop Body
- 2) RJ-501107-1.....12mm-1.75 x 50mm Long Flanged Hex Bolt



Installation Instructions

Step 1

Start by safely supporting your vehicle and removing your front coil springs, as well as any extended bump stop equipment that your vehicle is currently equipped with at the frame, and/or the axle.

Step 2

Remove the stock jounce bumpers from your chassis and retain them for reuse.
If it so happens that these pieces have already been removed from your vehicle - new ones can be obtained from Mopar / the Jeep dealership under Mopar part number: 68480876AA



WWW.ROCKJOCK4X4.COM

@ROCKJOCK4X4 /ROCKJOCK4X4 /ROCKJOCK4X4BYJOHNCURRIE

Step 3

The billet aluminum upper bump stop spacer fits into the bump stop cup in the frame that the stock jounce bumper was removed from. The aluminum spacer features a threaded hole in the top that the supplied 12mm bolts thread into, and a bore in the bottom where the stock jounce bumper installs back into it.

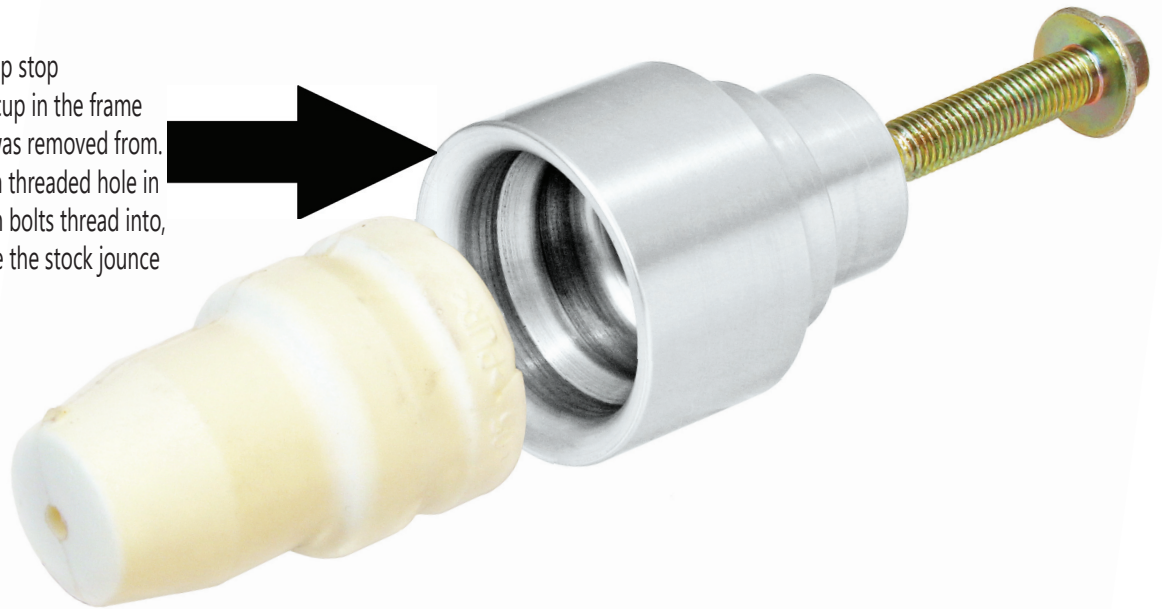

Step 4

Two 12mm-1.75 x 50mm long flanged hex head bolts are included in the kit. These bolts drop in from the top side of the upper bump stop frame tube (as shown on below) and then thread into the threaded hole in the top of the billet aluminum lower bump stop halves.

Simply tighten the bolt, which will pull the aluminum spacer up into the frame bore and torque the bolt to 48 ft. lbs.

Finish up by reinstalling the jounce bumpers into the bottom bores in the aluminum spacers.

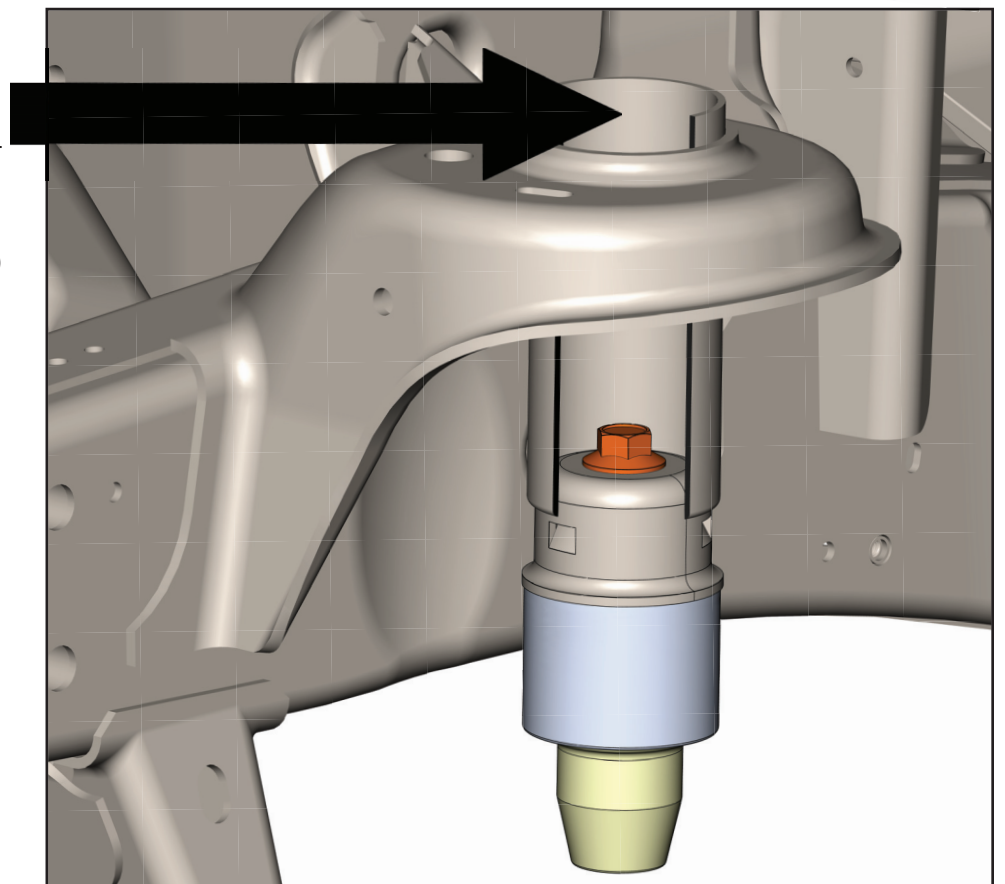
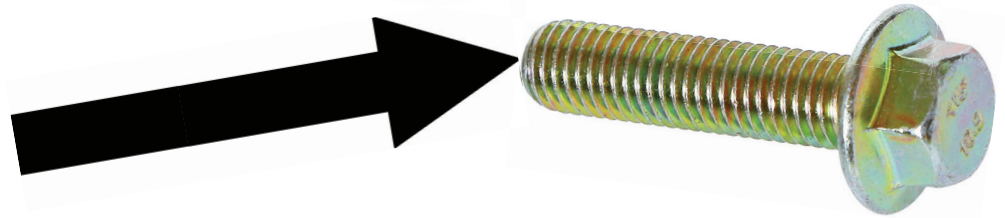

Step 5

As you can see by the diagrams below, as front axles articulate, axle mounted bump stops rotate inward, often missing the upper bump stop entirely. With a fixed, extended upper bump stop, you are guaranteed efficient bump stop function.

